

Electromagnetic Platform Stabilization for Mobile Robots

Eric Deng and Ross Mead

University of Southern California
3710 McClintock Avenue, Los Angeles, CA 90089-0781
deng@usc.edu, rossmead@usc.edu

Abstract

This work explores possible applications of electromagnetic platform stabilization (EPS) in systems suffering from vibration and resonance along multiple axes. Many HRI platforms are coupled rigid-body platforms; an EPS system acts as a non-rigid coupling between the mobile base and the upper-body structure. Electromagnets have many qualities that have been shown to perform well in complex mechanical systems; our initial investigations illustrate the utility of EPS technologies for reducing resonance in mobile robot platforms, particularly in human-robot interactions, in which sensors in the upper-body structure must be stable to track human users.

1. Introduction and Background

A key feature in many mobile robot platforms is navigation; however, motion during navigation often introduces vibration into the system. Critical components of mobile platforms require precise sensing capabilities, and excessive vibration from motion can significantly impair the system and limit overall performance. Sensor data are often stabilized in software, adding constraints to the computing capabilities of the robot; however, future applications in mobile robotics could reduce vibration in hardware using physical mechanisms. This would enable the deployment of more sensitive sensing equipment while freeing computation required.

This work proposes an approach for electromagnetic platform stabilization (EPS), a hardware innovation that enables stable operation of systems suffering from vibration. For us, the need for EPS arose while working on a custom mobile remote presence (MRP) system, consisting of an iRobot Ava Mobile Robot Platform with custom computation (for processing), tablet display (for touch input and visual output), and Microsoft Kinect (for person-tracking and speech recognition), illustrated in Figure 1. During mobile operations, the omni-wheels of Ava created a vibration throughout the system, which caused excessive pitch in the top-mounted structure of the robot, resulting in Kinect person-tracking failures in human-robot interactions (HRI).



Figure 1: iRobot Ava Mobile Robot Platform with custom mobile remote presence interface and Microsoft Kinect sensor.

After trying a variety of hardware and software design changes with less-than-optimal results, we decided to investigate a more fundamental change in our design—thus, EPS. EPS is a proposed design concept for mounted platform stabilization. The general structure of a *mounted platform* involves a system of two or more parts: one of which is a *moving base*, and the second is an *auxiliary system* that may include interfaces, sensors, and other peripherals (Figure 2).

The EPS system acts as a physical bridge between the inherently unstable moving base and the auxiliary system, minimizing the amount of vibration transferred between them. The basic physical structure of an EPS system consists of a ball-and-cup connection with the ball joint being elevated in the cup joint through a rigid, physical connection. This physical connection can be a hard solid-on-solid contact, a taut cloth-like suspension connection, or even a strong magnetic connection; the flexibility in this connection allows for interesting stabilization techniques, discussed below. Variable-strength electromagnets are embedded within the cup joint, and can be controlled to mitigate the vibrations being transferred between the moving base and auxiliary systems.

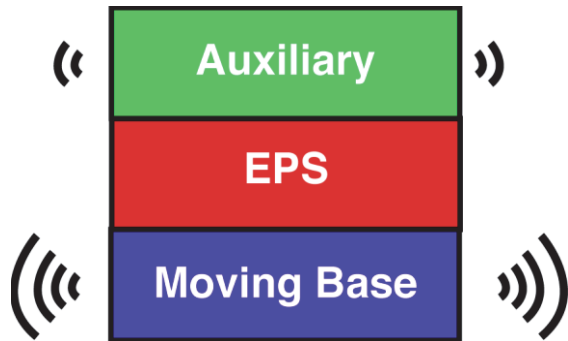

Figure 2: Basic configuration of an EPS-enabled system.

Traditional solutions to this dynamics problems consider using rubber-like materials to absorb vibrations, as well as control systems for an inverted pendulum and multi-dimensional inverted pendula. While there have been attempts at solving vibration transmission in dynamic conditions such as our use case, the EPS solution combines controls of electromagnets and a physical joint with limited range of motion to provide a simple and effective solution. The deployment of EPS systems on mobile robot platforms provides a stable platform upon which sensors and computation can be effective for real-time applications.

2. EPS Physical Structure

This section introduces the physical model and discusses the benefits of the proposed EPS system.

2.1. Physical Ball-And-Cup Joint

The general design of the connection between the base and auxiliary of the EPS system is a ball-and-cup joint (Figure 3). This design allows for coarse control of the range of motion by changing the ratio of the radii of the ball and cup; however, as the design can be used in a variety of applications, some of which involve objects of larger mass, the connection can be constructed to include suspension systems.

2.2. Suspended Ball-And-Cup Joint

With a suspended ball-and-cup joint (Figure 5), we can use the tension of the suspension system to control the range of vertical motion while also fine tuning the actual range of roll, pitch, and yaw motion of the system as the vertical motion varies. The controls and physical hard-stops for the roll, pitch, and yaw are controlled the same way, and the implementation of this suspended ball-and-cup joint further limits the amount of vibrations being transferred through the joint.

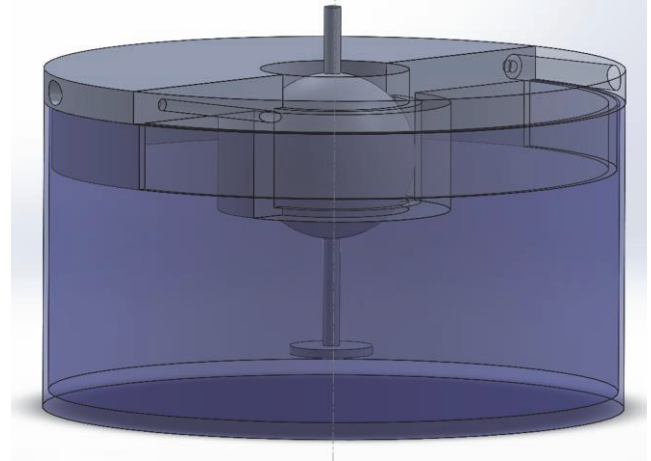

Figure 3: A 3-dimensional model of the physical EPS structure.

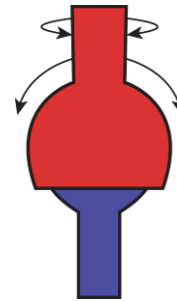

Figure 4: Classic ball-and-cup joint.

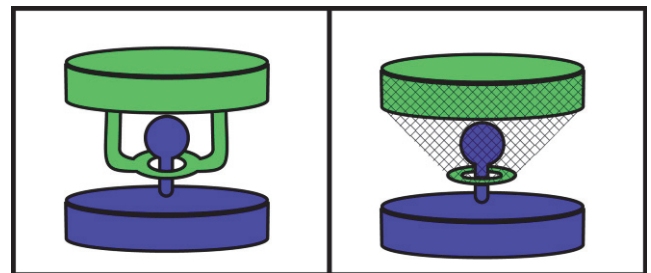

Figure 5: Physical ball-and-cup joint (left) vs. suspended ball-and-cup (right)

2.3. Magnetic Stabilization

Now that the system is suspended and free to move around in the ball-and-cup joint, we use n (where $n > 1$) electromagnetic pairs to control how the system is allowed to move within the physically-defined bounds (Figure 6). This design with n pairs allows for more freedom in application (Figure 7). When cost and packaging is a concern, such as in consumer products, fewer magnetic pairs may be used; however, for deployments in which accuracy is crucial, such as in industrial settings that require fine adjustments and control, more sets may be used for precision.

We can even use variable-strength electromagnets to form these electromagnetic pairs (Nagaya, 1995). By controlling the strength of each electromagnetic pair, we can implement a system that varies the strength of the resistive force in each axis of motion to minimize the transfer of vibrations from the base to the auxiliary system. The structure the system could be implemented is described in Section 3.2.

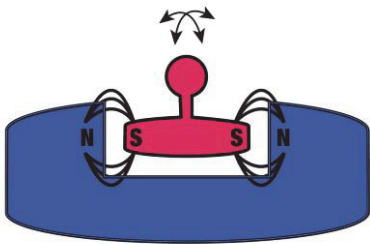

Figure 6: Electromagnetic pairs line the concentric walls of the EPS system. A pair consists of one electromagnet on the outer wall, and one ferromagnetic metal part on the inner wall.

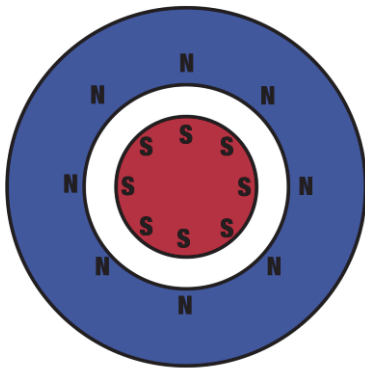

Figure 7: Electromagnetic pairs numbering n located along the sides of the EPS structure.

2.4. Control Range of Motion

If the desired limits in different axes are different, the ball-and-cup joint design is ideal. By simply changing the shape of the opening in the cup joint, we can define the maximum displacement of the ball joint for each $\Theta \{0^\circ \leq \Theta \leq 360^\circ\}$.

3. Controls for Stabilization

Like previously mentioned, because the control of pitch, yaw, and roll is controlled by the electromagnetic pairs and these pairs can be made of variable-strength electromagnets, we can build incredibly complex and specialized systems for more specialized use cases. The control systems and implementation is described in the following sub-sections, as well as the controls for the inverted pendulum problem.

3.1. The Classic Inverted Pendulum Problem

Stabilization of the Inverted Pendulum (Stimac, 1999) is a problem that is often proposed in high-level dynamics as a classic example of Lagrangian Dynamic Analysis (LDA) because the inverted pendulum can be theoretically modeled using LDA techniques.

After performing LDA on the desired model of an inverted pendulum system, one can build a model that uses the encoded information on the drivetrain of the moving base to tune the controls that describe the overall motion of the base in each axis. A simple outline of the schematic of a proposed pendulum-cart system (Stimac 1999) is illustrated in Figure 7. This model is a theorized 1-dimensional example for easier understanding but the same concept has been extrapolated and validated in much more complex systems—one of which being the flying inverted pendulum (Hehn and D'Andrew 2011), an extension of the classical problem by balancing the inverted pendulum on top of a quadrotor aerial vehicle. (Figure 8)

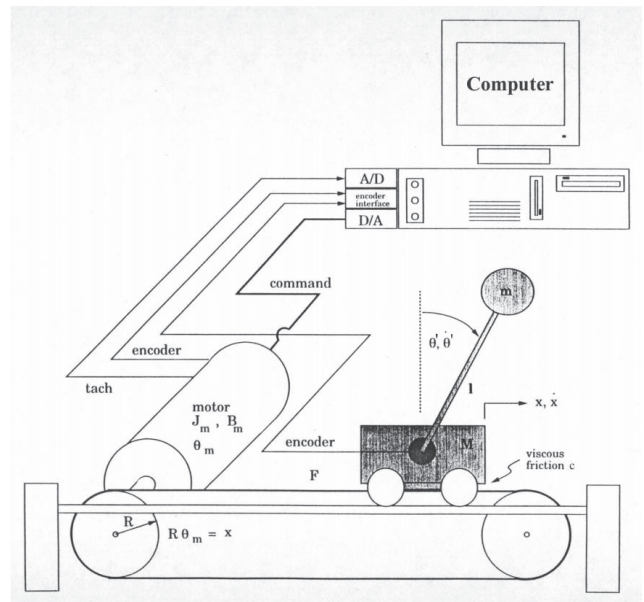

Figure 8: Schematic of classic inverted pendulum (Stimac 1999).



Figure 9: Demonstration of a flying inverted pendulum.

Our first attempt at handling the vibrational noise that we were seeing was actually a basic version of the inverted pendulum problem. There were certain speeds at which the whole system would shake violently, so we added some changes to the controller that minimizes the amount of time that the robot spent at those velocities. Ultimately, our efforts led to a system that still underperformed; we are in the process of improving the system in our ongoing work.

3.2. Variable-Strength Electromagnets

Using these electromagnets (Figure 10), we can design a controller that changes the current through each electromagnet based on relevant factors such as velocity, masses of the base and the auxiliary system, and models of floor materials.

Using this model of the strength of the magnetic force of an electromagnet and generalized models of the relationship between the motion of the system (including previous velocity and acceleration) and the floor surface and resonance, we can implement a resonance matching control system, similar to an inverted pendulum model (Figure 8).

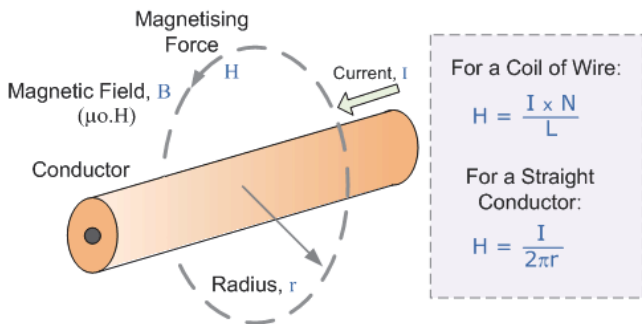

Figure 10: Generalized model of an electromagnet, like that proposed for EPS.

3.3. Resonance-Matching System

As the system uses electromagnets to mitigate vibrations and as electromagnets can be built and controlled with extreme precision and speed, an effective feedback system can be implemented that matches the vibrational frequencies of the platform with the resonant frequency of the electromagnetic system. The proposed system is shown in Figure 10.

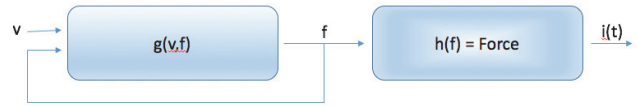

Figure 11: High-level system design.

The amount of control is flexible and the models being implemented can be tuned to be within the desired tolerance of the user. The range of control is determined by the accuracy of the model. The vibration of the platform along a particular axis is determined by the current motion (e.g., velocity, acceleration, jerk, etc.), the physical properties (e.g., mass, center of mass, etc.), the previous amount of vibration along that axis, and the surface of motion. We are in the process of collecting data to build a model (g) to implement a system that controls the force of the electromagnetic pairs along each axis to minimize the vibrations along the axis (h).

Once a model of h is constructed, we will develop a general model for countering vibrations by changing the resonant frequency of the system, which is saved as future work.

4. Summary and Conclusions

We proposed the physical design of an EPS system and discussed the considerations for a ball-and-cup joint modified for a variety of use cases. We then proposed the controls for stabilization of the system, as well as a high-level design of EPS based on related work with inverted pendula and the general model of a variable-strength electromagnet.

Many mobile robots suffer from vibrations transferred from the moving base to mounted sensor suites, which impacts the performance of the system. The proposed EPS system serves as an experimental option for generalized platform stabilization for mobile robots.

Acknowledgements

We thank Prof. Bingen Yang for his valuable insights on the physical design and controls, and Caitlyn Clabaugh for her assistance in visualizing the proposed system.

References

- Hehn, M. and D'Andrea, R. 2011. A flying inverted pendulum. 2011 IEEE International Conference on Robotics and Automation (ICRA 2011), 763–770.
- Nagaya, K. and Sugiura, M. 1995. A method for obtaining a linear spring for a permanent magnet levitation system using electromagnetic control. IEEE Transactions on Magnetics, 31(3): 2332–2338.
- Stimac, A.K. 1999. Standup and Stabilization of the Inverted Pendulum. Massachusetts Institute of Technology.